

The GENERAL RADIO EXPERIMENTER

VOL. 3 NO. 5

OCTOBER, 1928

The General Radio Experimenter is published each month for the purpose of supplying information of particular interest pertaining to radio apparatus design and application not commonly found in the popular style of radio magazine.



There is no subscription fee connected with the General Radio "Experimenter." To have your name included in our mailing list to receive future copies, simply address a request to the GENERAL RADIO CO., Cambridge, Mass.

The Development and Use of the Hydrophone

By HORATIO W. LAMSON, Engineering Department

PART III

In previous issues of the Experimenter we have traced the development of the two-spot hydrophone wherein one underwater-sound receiver is connected to each ear of the observer, and have seen how the principle of binaural compensation may be employed to advantage in such a device.

One serious drawback to the two-spot type of hydrophone is the fact that it has no directional selectivity since, obviously, the two sound-receiving units, such as hollow rubber spheres, must be equally sensitive to sounds from all directions. If there were only one source of sound in the field of observation no difficulty would be encountered, but when, as is generally the case, there exists a multiplicity of sounds from various origins, the presence of a loud sound hinders or prevents altogether an accurate balance upon a weak

sound in some other direction. The elimination of this handicap represents the next step in the development of the hydrophone art.

Suppose we take eight similar hollow rubber spheres and mount them at equal intervals along a straight horizontal beam as is indicated in

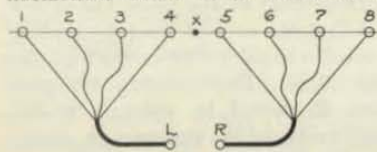

FIG. 1

Figure 1. Suppose, further, that the first four of these receivers are joined by equal air-filled pipes to a stethoscope applied to the left ear of the observer, while the second group of four receivers lead through pipes of the same length to a stethoscope applied to his right ear. If, now, this beam is suspended horizontally in the sea and a sound is traveling in a direction perpen-

dicular to the beam, then each advancing wave-front will strike all eight receivers simultaneously, assuming, of course, that the sound is distant enough so that the wave-front may be regarded as a plane. Under these conditions the four individual sound impulses picked up by receivers 1 to 4 will arrive simultaneously at the left ear of the observer, whereat, according to a fundamental law of physics, they will augment each other to give a composite impulse of maximum intensity. The same phenomenon will occur simultaneously at the right ear of the observer so that he will perceive this particular sound coming from a direction perpendicular to the beam, to be both BINAURALLY CENTERED AND OF MAXIMUM INTENSITY.

Consider now the effect of a sound traveling in any direction which is not perpendicular to the beam. In this case each advancing wave-front does not strike all receivers simultaneously but rather in sequence at intervals depending upon the direction of travel with respect to the beam. As a result the four individual impulses in each ear are not simultaneous so that, by the well-known principle of interference, they give a composite response of diminished intensity. Furthermore, since one group of receivers is, as a whole, excited before the other group,

HAS YOUR SUBSCRIPTION EXPIRED?

There is no charge for the "Experimenter," but in order to avoid waste we ask your cooperation in expressing to us once a year your desire to continue to receive copies each month.

Except in the case of names which have been placed on the mailing list since July 1, a card has been enclosed with this issue. If you desire to continue to receive the "Experimenter" please fill out the enclosed card, stamp it, and return it to us promptly. After the next issue no further copies will be sent except to those who have returned cards, or who have made their original request to be placed on the mailing list since July 1, 1928.



IET LABS, INC in the GenRad tradition
534 Main Street, Westbury, NY 11590

www.ietlabs.com
TEL: (516) 334-5959 • (800) 899-8438 • FAX: (516) 334-5988



the observed sound will appear binaurally off center to the observer.

If this beam can be rotated horizontally in the sea about its midpoint X we have a binaural device known as the MB-tube which is identical in its operation with the C-tube with the added feature of directional selectivity. The letters MB designate a multiple-unit device focusing broadside to the beam.

Both the C-tube and MB-tube focus at any one time on two directions perpendicular to the beam on either side. This ambiguity can,

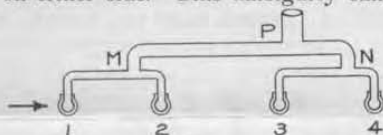
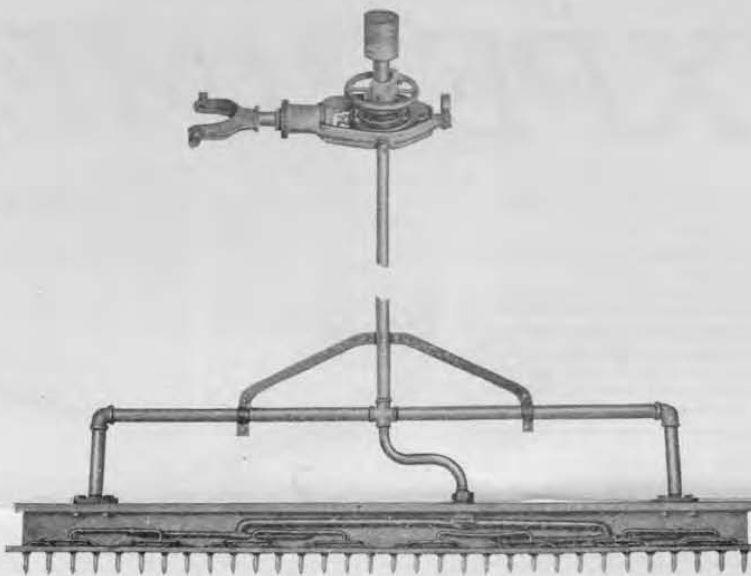

FIG. 2

in a multi-spot device, be ingeniously eliminated in the following manner. Referring to Figure 2, consider the four sound receivers as indicated equally spaced in a horizontal line. Assume now that we have a sound wave traveling along the line of receivers in the particular direction indicated by the arrow. In the pipe 1-2 place a take-off junction M at such a position that, for each wave of the sound in question, the impulse picked up by receiver 1 after traversing the longer pipe length 1-M will arrive at the junction M at the same instant that this wave traveling through the water from receiver 1 to receiver 2 and thence through the shorter pipe length 2-M will arrive at M. These two impulses arriving simultaneously at the junction point will, of course, augment each other to give a maximum response in the take-off pipe. A similar take-off junction N is located in the pipe 3-4 at the point where a maximum response is obtained from receivers 3 and 4. The points M and N are now connected by another pipe having a junction point P at such a position that a given composite impulse from M arrives at P at the same instant as the corresponding composite impulse arrives from N. Thus, at the junction P, which may be led to one ear of the observer, we obtain a maximum response for sound traveling in the direction indicated by the arrow, whereas, for sound traveling in any other direction, the four impulses will not be simultaneous at P, giving rise to interference and a diminished intensity.

Imagine now that we have a duplicate line of four receivers mounted beside and parallel to the first line, giv-



ing an H-type structure, and joined to the other ear of the observer. We will have then a binaural hydrophone possessing a UNIDIRECTIONAL SELECTIVITY. Such a device is known as an MF-tube, designating a multi-spot unit focused forward along the beam.

It is worth noting in passing that, in accordance with the acoustical law of "conservation of areas," the cross-sectional area of the pipe M-N should be twice that of the pipes 1-2 or 3-4 and that the area of the pipe leading from P should be twice that of the pipe M-N. Furthermore, the pipe from P should be reduced to the small orifice of the stethoscope gradually by means of conical piping.

For simplicity we have described MB and MF-tubes utilizing four receivers to each ear. In practice greater selectivity is obtained by

combining, in a similar manner, a larger number of receivers. The illustrations show two forms of the MF-tube employing thirty-two receivers to each ear. These receivers take the form of cylindrical rubber nipples rather than spheres.

Both the MB and the MF-tubes must, of course, be lowered into the sea and rotated to make an observation, which is a serious handicap in their use. The question will at once occur to the reader: why not use a fixed line of receivers and by means of compensation, as in the case of the two-spot, focus them in groups for any particular direction? This is exactly what is done in the modern type of hydrophone known as the MV, designating multiple-unit with variable compensation. We shall examine how this is accomplished in a subsequent issue of the EXPERIMENTER.

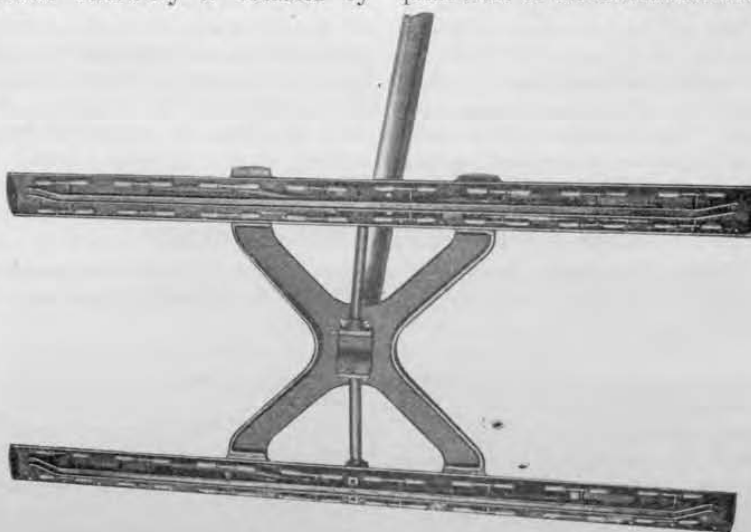



A New Test Oscillator



There has just been added to the General Radio Co. line of apparatus a test oscillator for aligning and adjusting receivers. While this instrument has general application, it is particularly suited for servicing the Radiola 60, and was designed with the service requirements of this receiver in mind. The Type 320 test oscillator should therefore be of particular interest to distributors and service stations handling this and similar receivers.

The General Radio Type 320 180 K. C. Test Oscillator consists of a radio frequency oscillator having three frequencies, and a fixed modulation frequency. A milliammeter is provided to assist in making receiver adjustments. It is not connected in the oscillating circuit. A non-metallic screw driver, leads and coupling coil are supplied with the oscillator. A standard tube with the heater circuit open-circuited, but with the elements in position is required for neutralizing. This is not included in the oscillator equipment.

The Type 320 180 K. C. Test Oscillator is particularly adapted to the servicing of the Radiola 60 or other superheterodynes operating on 180 kilocycles (eg. Brunswick-Type 5 NO and Graybar Type 330 receivers,) a 180-kilocycle frequency being provided for adjustment of the intermediate frequency stages of that receiver. The 180-kilo-

cycle frequency is accurately set. Complete instructions for using the oscillator in servicing the Radiola 60 are contained in instructions issued by the Radio Corporation for this receiver.

As shown in the circuit diagram, the Type 320 180 K. C. Oscillator consists of two oscillator coils with a selector switch for shifting frequency, and three condensers. Modulation is accomplished by means of a grid leak and condenser. Three radio frequencies are provided, 180-kilocycles, 640 kilocycles and 1400 kilocycles. The 180-kilocycle oscillator is accurately adjusted to that frequency in order that it may be used in lining up condensers in an intermediate-frequency amplifier operating on this frequency.

While the Type 320 180 K. C. Test Oscillator is so designed as to be particularly useful in the testing of Superheterodynes operating on a 180 kilocycle intermediate frequency, its use is not limited to the testing of such receivers. The two radio frequencies, one at each end of the broadcast band, may be used as a source in neutralizing and aligning any type of receiver.

The variable condenser is supplied in order that the intermediate frequency may be swung slightly to either side of 180 kilocycles as required in adjusting the intermediate-frequency amplifier. The frequency is accurately adjusted to 180 kilocycles with this condenser set on the indicator.

A New Junior Engineer

C. E. Worthen, a recent graduate of the Massachusetts Institute of Technology, has joined our engineering staff. As an undergraduate Mr. Worthen specialized in electrical communications, and will continue here in similar work on instrument development. He is at present engaged in the design of a 400-cycle fork-driven oscillator of good waveform, similar to our standard 1,000 cycle unit.

Characteristics of Electrical Pickups

Considerable interest has been shown recently in the possibilities of the electrical reproduction of phonograph records, especially by using the amplifier and reproducer of a radio receiver or a separate amplifier intended for the particular purpose in conjunction with a turntable and a pick-up of the magnetic type.

The whole scheme of electrical reproduction may be divided into a number of different phases starting from the record, which we are forced to accept as it is, passing on to the pick-up, then to the audio frequency amplifier and finishing at the reproducer. Several excellent articles have appeared in various publications concerning amplifiers and since it is possible, with comparatively little trouble, to make a very satisfactory amplifier as long as we do not want excessive overall amplification, this phase of the subject calls for very little discussion. The present day reproducers are by no means perfect yet, but the modern types of cone and dynamic speakers are capable of very satisfactory results.

This now leaves us with the consideration of the pick-up, the duties of which may be briefly stated as follows: To convert in some manner the movements of a needle in a groove of a record into variations of electrical potential so that the variations are equivalent to the ripples of the record. Of all the various methods of conversion the moving-iron electromagnetic type of pick-up seems to be the most popular. Whatever method of conversion is used, certain mechanical considerations must be taken into account.

(a) The needle must follow the record groove exactly.

(b) The speed of the record should be constant.

(c) The effective weight of the pick-up must be great enough to satisfy conditions (a) but not enough to cause undue wear of the record.

(d) Damping on each side of the position of rest should be equal for equal amplitudes.

(e) Mechanical resonances of the needle and its attachments must be so minimized as to have no effect on the output of the pick-up.

These conditions may seem self-evident but they are extremely im-



portant and all are quite closely connected with each other. For instance, if the damping of the needle is made very high (in order to eliminate unwanted resonance in the moving-iron system) then the effective weight of the pick-up must be made fairly large in order to keep the needle in the groove. This, in turn, will lead to excessive wear. On the other hand, if the effective weight of the pick-up is not made greater than that of a conventional sound-box, and if high damping is used, the needle will probably not follow the groove when it has a fairly large amplitude of movement but will have a tendency to jump the groove or scratch the record. The term "effective weight" has been used to mean the weight on the needle. An extra heavy pick-up, of course, may be counterbalanced by weights on springs so that the effective weight can be made variable.

Probably the most important problem in the consideration of the electrical characteristics of a pick-up is the elimination of resonance points. In a damped-reed type of pick-up the natural frequency of the reed should be made high so as to obviate trouble due to overtones. A simple reed fixed at one end will be, of itself, very stiff without artificial damping. In the moving-iron system the iron armature is usually pivoted so that it is quite free to move in one plane. Damping is then applied, usually at the end not carrying the needle.

It is desirable in conjunction with most commercial pick-ups partially to suppress the higher frequencies in order to reduce surface noise or scratching. This is usually accomplished by connecting a choke and condenser in series across the output of the pick-up. A shunt circuit of this description should be tuned to around 4000 to 4500 cycles. This suppression of high frequencies is at the cost of some overtones, especially in speech, but gives a most pleasing result, especially with musical numbers.

NEW LABORATORY CATALOG

A new catalog of measuring equipment listing a number of new items has just been printed and mailed to those who have requested it. This catalog is designed for manufacturers, schools and testing laboratories. There will be no general mailing of this catalog, but it will be gladly sent on request.

Some Old Principles in Audio Amplifier Design

FIG. E

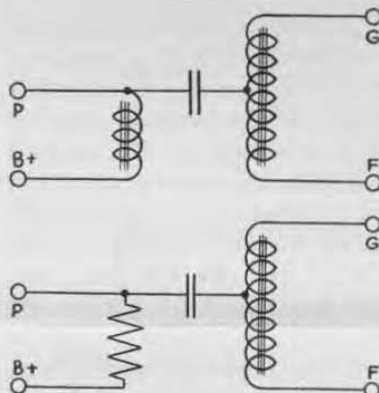

Evolution is a process that may be traced in radio circuits, whatever its status elsewhere, and the development of radio inventions presents an interesting study which might be indulged in by patent-office examiners to the benefit of the industry. The writer was somewhat startled a short time ago to see the circuit at the head of the column featured in one of the leading radio publications under the title "A New Principle in Audio-Transformer Design." A vague memory sent us to the files of the "Experimenter," where the May 1927 issue revealed the figure shown above, with the following comment.

"The methods of Figure A and B can be modified as shown in Figure C.

Dr. Frayne Awarded Fellowship

It is with mixed regret and pleasure that we announce that Dr. John G. Frayne, of our engineering staff, has been granted a leave of absence until next spring to accept a fellowship at the California Institute of Technology.

Dr. Frayne joined our organization last spring and has been investigating the possibilities of the industrial control of the flow of gases by noting the change in dielectric constant.

While we regret the temporary loss of Dr. Frayne, we share with him his pleasure in being awarded a fellowship which will enable him to study further the recent advances in physics. Before coming to the General Radio Co., Dr. Frayne was Professor of Physics at Antioch College.

In these circuits, an impedance is used in place of a resistance in the output circuit. This arrangement is recommended where there is danger of grid current flowing momentarily, as on occasional loud signals, particularly in the last amplifier stage.

"In the circuit of Figure C, the plate and grid coils are generally on different cores and are not magnetically coupled to each other. In Figure D, both coils have been put on the same core to form a 1:1 transformer, but the condenser has been retained and provides sufficient capacitive coupling at high frequencies to reduce any tendency toward resonance at high frequency due to magnetic leakage.

"In the circuit of Figure E, advantage is taken of the step-up in voltage obtained by the auto-transformer connection. This feature increases the volume per stage, and may be combined with any of the systems of Figures A to D."

A more recent and complete discussion of the same circuit, using an inductance in the plate circuit appeared in the April 1928 issue under the head "Parallel Plate Feed."

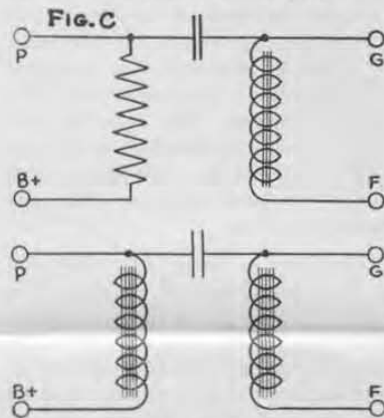

Let it not be thought, however, that the Experimenter claims any originality in this connection. The article referred to was purely historical. The circuit is much older, and appeared in "QST" in 1919 or 1920, and was probably not new then.

It is interesting to observe how a circuit such as this, which possesses undoubted merit, is ignored for nearly ten years. Great credit is certainly due to the manufacturer who, to use his own happy phrase, has bewildered the industry by placing this circuit in a convenient single container "just two years in advance" of competitors, with the result that those who come to scoff remain to pay.

